

MAGICART

How to be A Global Leader in Services?

Many of us are facing after-sales trouble no matter private or governmental control company, time is invaluable and most worrying for us. Once the machine shut down, the production shut down either, and we start to lose money quickly and come to an operation crisis So what we do here?

- ◆ Fast Action in Services
- ◆ Unconditional Parts Supply
- ◆ Strong Professionalism
- ◆ Spotless Satisfaction

This is how RISINGCRANE started to make business. What we do is giving the fastest services after supplying high-quality level products.

HENAN HONGSHENG CRANECO., LTD

河南鸿起重机有限公司

Email: hi@biey.com

whatsapp (wehat) : +86 15250500909

Phone: +86 15250500909

https://www.biey.com

地址：中国-河南省长垣市魏庄办事处纬三路3号

About Us

RISINGCRANE is a leading manufacturer and service provider of cranes and material handling equipment, dedicated to the R & D, design, manufacturing, installation and service of cranes and material handling technology.

RISINGCRANE owns comprehensive products, reliable quality, excellent performance, efficient service. The products are distributed in more than 30 countries and regions around the world. It is widely used in more than 20 professional fields, such as equipment manufacturing, logistics, energy, electric power, shipbuilding, metallurgy, ports, infrastructure, metal processing, hydropower stations, automobile manufacturing, and aerospace.

RISINGCRANE's main products are overhead crane, gantry crane, rubber tyred gantry crane, portal jib crane, dock arm, jib crane, electric hoist, customized crane system and lifting accessories. RISINGCRANE has saved customers huge cost in machine purchase and life cycle operating after long-term technological innovation.

Through long-term unremitting efforts, RISINGCRANE will provide clients with the best cost-effective products to fulfill its mission: **promote client's business!**

- ☑ Single Girder Overhead Crane (1~12.5 ton)
- ☑ Double Girder Overhead Crane (5~800 ton)
- ☑ Suspended Overhead Crane (1~12.5 ton)
- ☑ Monorail Overhead Crane (500kg~10 ton)



EOT - Single Girder Overhead Crane

◆ Sketch for Info Checking

DIMENSION

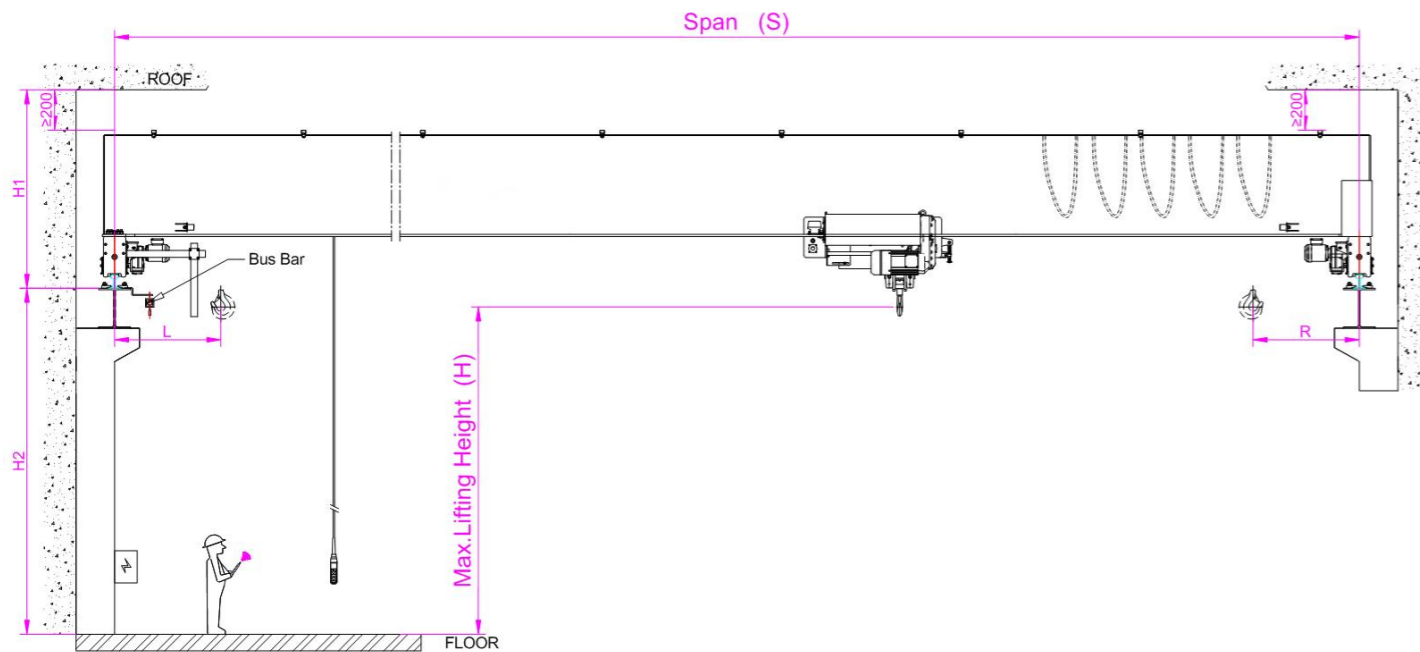

CRANE LAYOUT

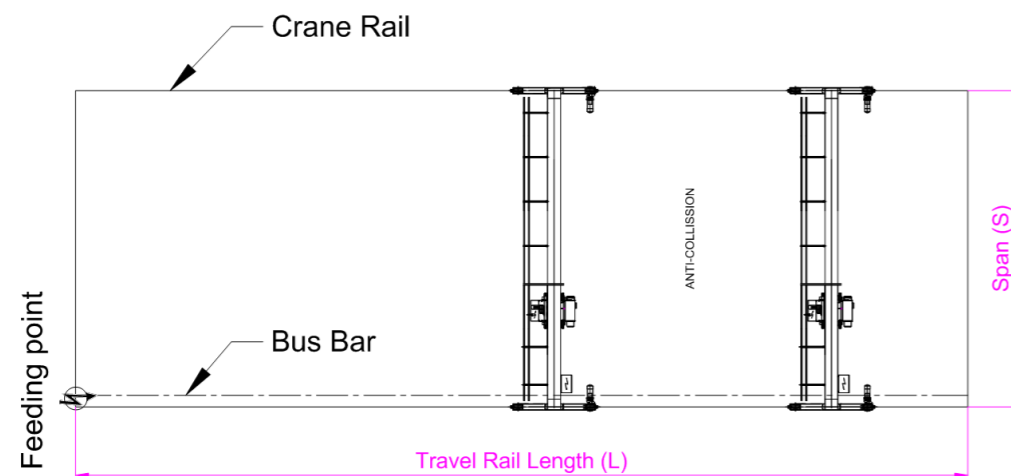

1) Necessary Info needed from client for offer

- SWL / Load Capacity
- Span (S)
- Max. Lifting Height (H)
- Travel Rail Length (L)
- Quantity of crane
- Power Voltage

2) More info needed from client if available

- Workshop Building Drawing or Size
- Height above H-beam (H1)
- Height under H-beam (H2)
- Pendant control or Remote control or Cabin control

Single Girder Overhead Crane

Capacity: 1 ~12.5 t

◆ **Economic Design** : LD model
Class : A3 / A4

◆ **European FEM Design** : CXTS model
Class : A5



SWL / Load Capacity (ton)	Span (m)	Max Lifting height (m)	Class
1	5~28.5	3~25	A3~A5
2	5~28.5	3~25	A3~A5
3	5~28.5	3~25	A3~A5
5	5~28.5	3~25	A3~A5
8	5~28.5	3~25	A3~A5
10	5~28.5	3~25	A3~A5
12.5	5~28.5	3~25	A3~A5
Customized	Customized	Customized	N/A

Option :

- Pendant control or Remote control
- Indoor or Outdoor
- Anti-explosion

EOT - Double Girder Overhead Crane

◆ Sketch for Info Checking

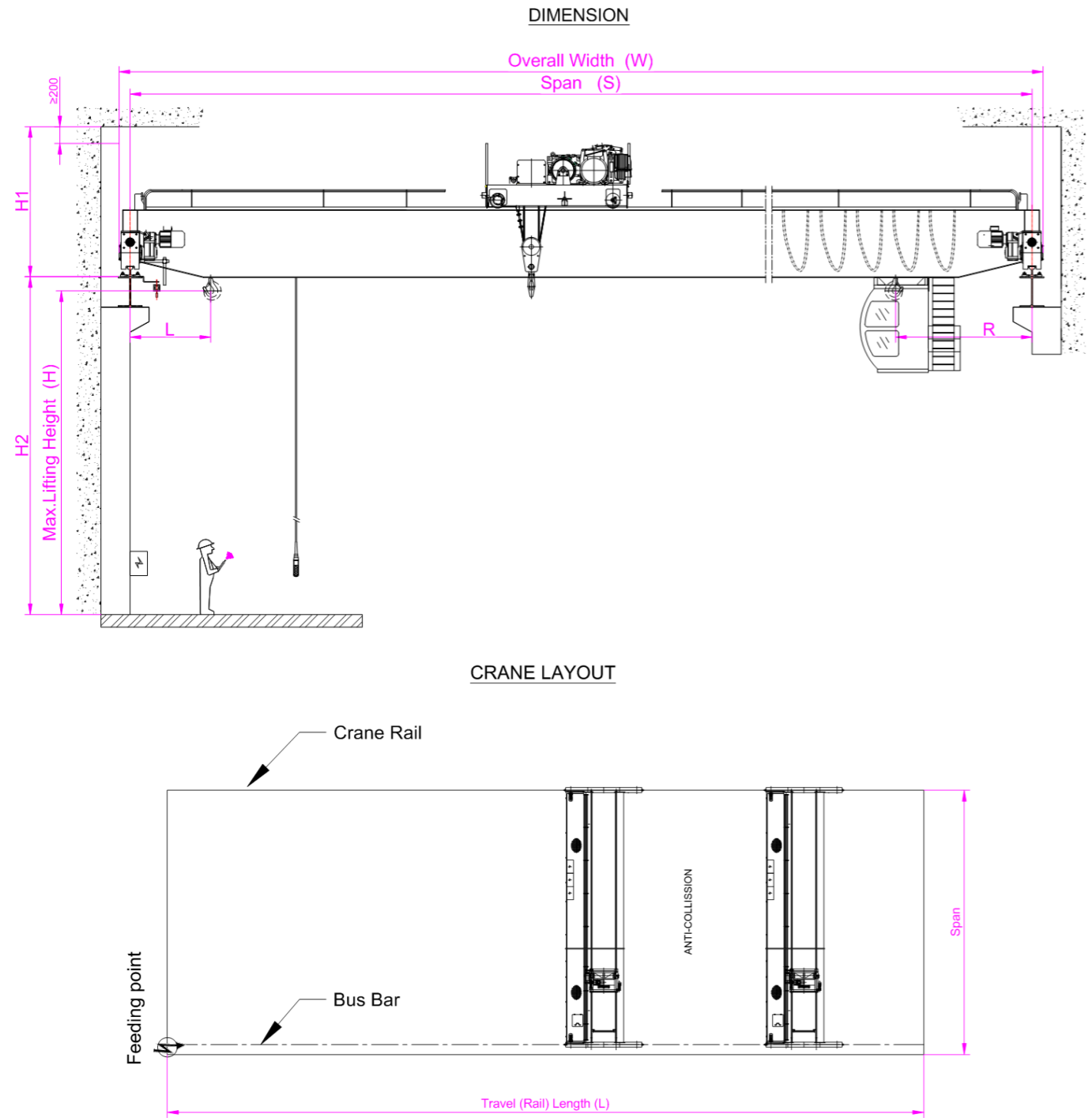

1) Necessary Info needed from client for offer

- SWL / Load Capacity
- Span (S)
- Max. Lifting Height (H)
- Travel Rail Length (L)
- Quantity of crane
- Power Voltage

2) More info needed from client if available

- Workshop Building Drawing or Size
- Height above H-beam (H1)
- Height under H-beam (H2)
- Pendant control or Remote control or Cabin control

Double Girder Overhead Crane

Capacity: 5~800 t

◆ Economic Design

Model : LH, QD
Class : A4, A5, A6, A7, A8

◆ European FEM Design

Model : CXTD, CXSM
Class : A5, A6, A7, A8



Capacity (ton)	Span (m)	Max Lifting height (m)	Class
5	5~28.5	3~25	A3~A5
10	5~28.5	3~25	A3~A5
15	5~28.5	3~25	A3~A5
20	5~28.5	3~25	A3~A5
30	5~28.5	3~25	A3~A5
50	5~28.5	3~25	A3~A5
80 ~800	5~28.5	3~25	A3~A5
Customized	Customized	Customized	N/A

Option :

- Pendant control or Remote control or Cabin control
- Indoor or Outdoor
- Anti-explosion

Suspended Overhead Crane

- ◆ Sketch for Info Checking

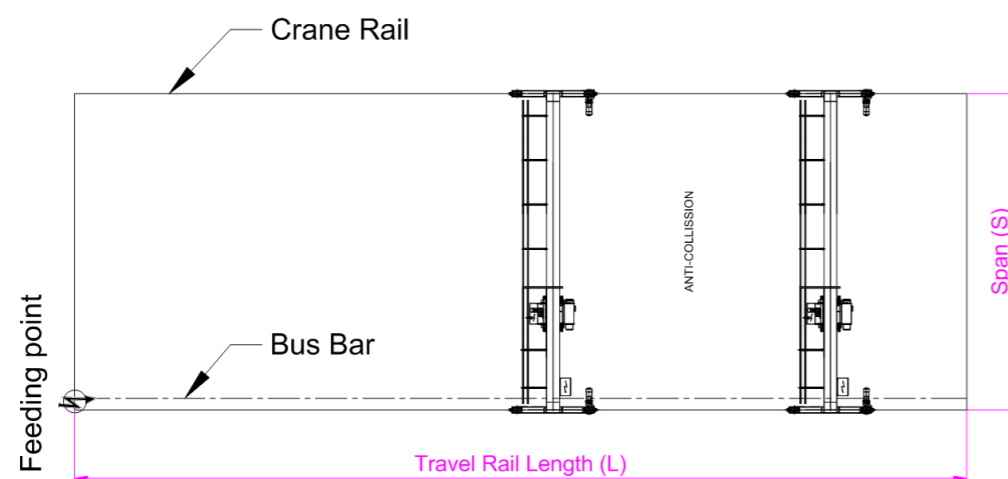
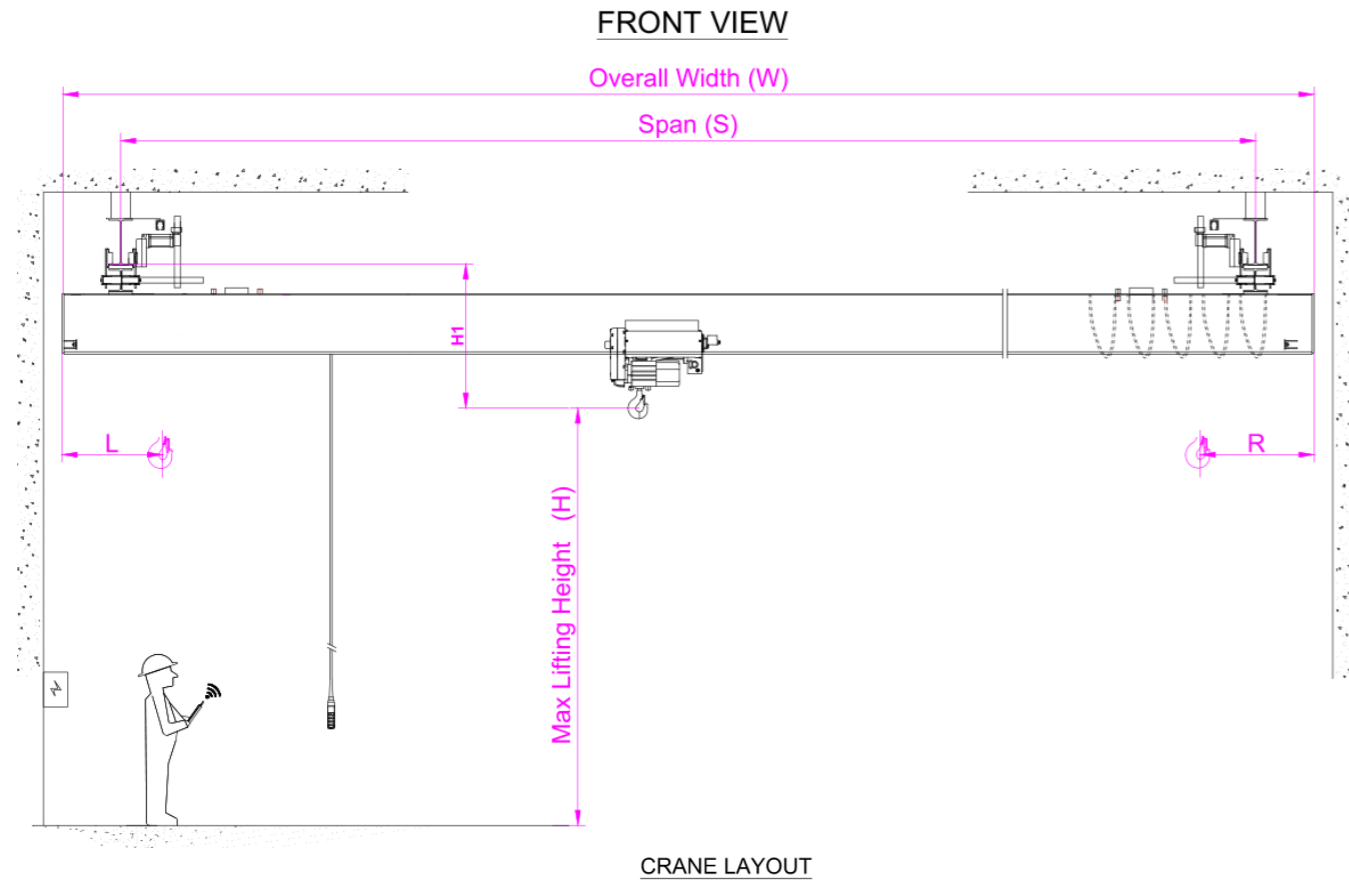

1) Necessary Info needed from client for offer

- SWL / Load Capacity
- Span (S)
- Max. Lifting Height (H)
- Travel Rail Length (L)
- Quantity of crane
- Power Voltage

2) More info needed from client if available

- Workshop Building Drawing or Size
- Pendant control or Remote control

Suspended Overhead Crane

Capacity: 1 ~12.5 t

- ◆ **Economic Design** : LX model
Class : A3

- ◆ **European FEM Design** : CXLX model
Class : A5



SWL / Load Capacity (ton)	Span (m)	Max Lifting height (m)	Class
1	3~28.5	3~25	A3~A5
2	3~28.5	3~25	A3~A5
3	3~28.5	3~25	A3~A5
5	3~28.5	3~25	A3~A5
8	3~28.5	3~25	A3~A5
10	3~28.5	3~25	A3~A5
12.5	3~28.5	3~25	A3~A5
Customized	Customized	Customized	N/A

Option :

- Pendant control or Remote control
- Indoor or Outdoor
- Anti-explosion

Monorail Overhead Crane

- ◆ Sketch for Info Checking

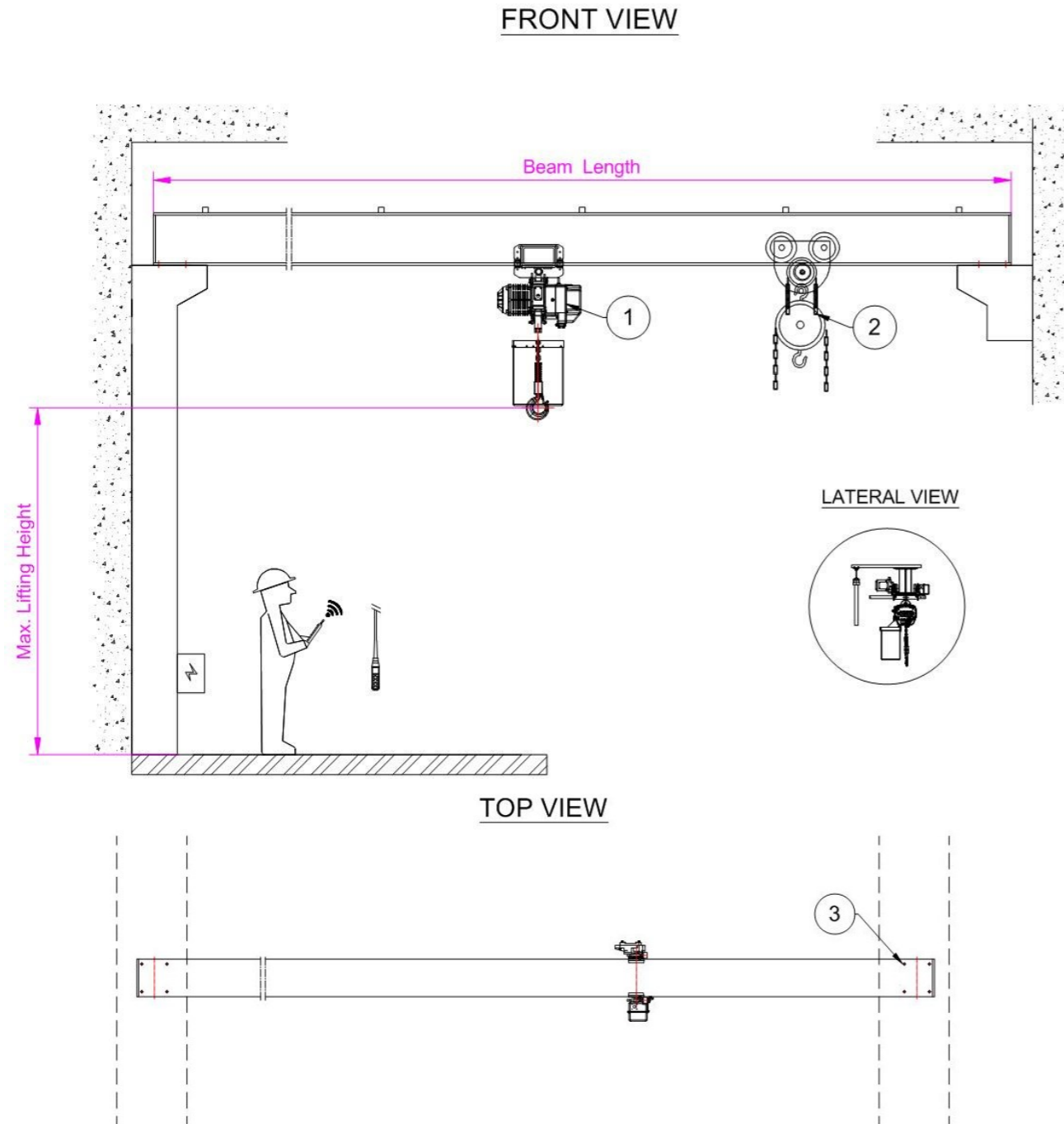

1) Necessary Info needed from client for offer

- SWL / Load Capacity
- Quantity of crane
- Beam Length
- Power Voltage
- Max. Lifting Height (H)

2) Parts name

- ① Electric chain hoist
- ② Manual chain block (option)
- ③ Bolt Mounting

Monorail Overhead Crane

Capacity: 500kg~10 ton



Capacity (ton)	Beam Length (m)	Max Lifting height (m)
0.5	2~25	2~120
1	2~25	2~120
1.5	2~25	2~120
2	2~25	2~120
3	2~25	2~120
5	2~25	2~120
10	2~25	2~120
Customized	Customized	Customized

Option :

- Pendant control or Remote control
- Indoor or Outdoor
- Anti-explosion
- Electric chain hoist or Manual chain block or Electric wire rope hoist or multiple layers winch

Why our proposal is so attractive?

Technology Advantages

- Advanced technology in crane structure design
- Advanced electric & hydraulic control system



Reliable Fast Services

- Solve-trouble firstly in company rules
- Professional & fast action in solution



Excellent Performance

- 100% performance tested in factory
- Continuous performance optimized plan



Guaranteed Quality

- Qualified components for every part
- 2 years warranty services



How to find out the best solution for lifting job?

Just Call +86 15250500909



hi@bi ey.com

Tel: +86 15250500909

HENAN HONGSHENG CRANES CO., LTD

<https://www.bi ey.com>